



- DE** Austausch der Regelungsplatine HCM-3 Art.Nr. 2745586
Austausch der Platine EWO Art. Nr. 2745894 BWL-1S(B)
- GB** Exchange of control PCB HCM-3 art. no. 2745586
Exchange of EWO PCB art. no. 2745894 BWL-1S(B)
- ES** Sustitución de la platina de regulación HCM-3 nº art. 2745586
Sustitución de la platina EWO nº art. 2745894 BWL-1S(B)
- PL** Wymiana płytki regulacyjnej HCM-3 nr art. 2745586
Wymiana płytki EWO nr art. 2745894 BWL-1S(B)
- IT** Sostituzione della scheda di regolazione HCM-3 cod. art. 2745586
Sostituzione della scheda EWO cod. art. 2745894 BWL-1S(B)
- RU** Замена платы системы регулирования HCM-3, арт. № 2745586
Замена платы EWO, арт. № 2745894 BWL-1S(B)
- GR** Αντικατάσταση της πλακέτας ρύθμισης HCM-3 Κωδ. πρ. 2745586
Αντικατάσταση της πλακέτας EWO Κωδ. πρ. 2745894 BWL-1S(B)
- HU** 2745586 term. sz.-ú HCM-3 szabályozó panel kicserélése
2745894 BWL-1S(B) term. sz.-ú EWO panel kicserélése
- SK** Výmena základnej dosky riadenia HCM-3 č. výt. 2745586
Výmena základnej dosky EWO č. výt. 2745894 BWL-1S(B)
- CZ** Výměna základní desky řízení HCM-3 výt. č. 2745586
Výměna základní desky EWO výt. č. 2745894 BWL-1S(B)



Durch den Betriebsschalter EIN/AUS am Gerät erfolgt keine Netztrennung!
Gefahr durch elektrische Spannung an elektrischen Bauteilen. Greifen Sie niemals an elektrische Bauteile und Kontakte, wenn das Gerät nicht vom Netz getrennt ist. Es besteht Lebensgefahr!
Arbeiten an elektrischen Bauteilen dürfen nur von einem zugelassenen Fachmann durchgeführt werden.
Eine Funktionskontrolle muss nach einem Platinenwechsel durchgeführt werden. Es besteht sonst die Gefahr von Personenschäden durch Fehlfunktionen des Heizgerätes.



The unit is not isolated from the mains by the ON/OFF switch on the unit!
Danger through 'live' electrical components. Never touch electrical components and contacts if the unit is not isolated from the mains supply. Mortal danger!
Only qualified persons are permitted to work on electrical components.
A functional check must be carried out after replacing the printed control board. There is otherwise a danger of personal injuries due to malfunctioning of the heater.



El interruptor principal ON/OFF no desconecta el aparato de la red eléctrica.
Peligro por componentes eléctricos bajo tensión. No toque nunca los componentes y contactos eléctricos si el aparato no está desconectado de la red. Existe peligro de muerte.
Los trabajos en componentes eléctricos deben ser realizados solamente por personal especializado y cualificado.
Debe realizarse un control de funcionamiento después de cada cambio de platina. En caso contrario existe el riesgo de daños personales debidos a averías del aparato de calefacción.



Użycie wyłącznika głównego WŁ/AUS na urządzeniu nie powoduje odłączenia od sieci zasilającej!
Niebezpieczeństwo spowodowane elektrycznym napięciem występującym na elektrycznych elementach konstrukcyjnych. Nie wolno nigdy dotykać elektrycznych elementów konstrukcyjnych i zestyków, jeżeli urządzenie nie jest odłączone od sieci. Istnieje zagrożenie życia!
Prace na elektrycznych elementach konstrukcyjnych mogą wykonywać tylko dopuszczeni i wykwalifikowani pracownicy.
Po wymianie płytki należy przeprowadzić kontrolę poprawnego działania. W innym przypadku istnieje niebezpieczeństwo wystąpienia szkód na osobach w wyniku nieprawidłowego działania urządzenia grzewczego.



L'interruttore di esercizio ON/OFF che si trova sull'apparecchio non effettua la sconnessione!
Pericolo a causa della tensione elettrica sui componenti elettrici. Non toccare mai componenti e contatti elettrici se l'apparecchio non è sconnesso dalla rete.
Pericolo di morte!
I lavori sulle parti elettriche devono essere eseguiti soltanto da parte di personale specializzato autorizzato.
Dopo la sostituzione della scheda è necessario effettuare un controllo funzionale. Diversamente rischio di danni alle persone per malfunzionamento dell'apparecchio di riscaldamento.



Выключатель ВКЛ./ВЫКЛ. на устройстве нет сетевого расцепителя т.е. не отключает его от сети.

Опасность поражения электрическим током на электрических частях оборудования! Запрещается касаться электрооборудования и контактов, если устройство не отключен от сети. Опасность для жизни!

Работы на электрооборудовании разрешается производить только специалисту, имеющему соответствующий допуск.

После замены платы необходимо произвести проверку работоспособности. В противном случае из-за неисправности отопительного устройства возникает опасность получения травм.



Μέσω του διακόπτη λειτουργίας ON/OFF στη συσκευή δεν πραγματοποιείται αποσύνδεση από το ηλεκτρικό δίκτυο!

Κίνδυνος από ηλεκτρική τάση σε ηλεκτρικά μέρη. Ποτέ μην αγγίζετε ηλεκτρικά μέρη και επαφές, όταν η συσκευή δεν είναι αποσυνδεδεμένη από το ηλεκτρικό δίκτυο. Κίνδυνος θανάτου!

Η εκτέλεση εργασιών σε ηλεκτρικά μέρη επιτρέπεται αποκλειστικά και μόνο σε εξουσιοδοτημένο ειδικό.

Έλεγχος λειτουργίας επιβάλλεται μετά την αλλαγή πλακέτας. Διαφορετικά υπάρχει κίνδυνος σωματικών βλαβών λόγω δυσλειτουργιών του λέβητα.



A KI/BE kapcsoló működtetése még nem választja le a készüléket a hálózatról! Életveszély! Áram alatt lévő elektromos alkatrészek! Soha ne fogjon meg elektromos alkatrészeket és érintkezőket, ha a készülék nincs leválasztva a hálózatról. Életveszély fenyeget!

Elektromos alkatrészekeken csak engedéllyel rendelkező szakember végezhet munkákat.

Kártyacsere után működésellenőrzést kell végezni. Máskülönben a fűtőkészülék helytelen működése miatt személyi sérülések veszélye fenyeget.



Hlavným vypínačom sa zariadenie nedá odpojiť od elektrickej siete!

Nebezpečenstvo úrazu elektrickým prúdom pri dotyku elektrických častí zariadenia. Ak zariadenie nie je odpojené od siete, nemanipulujte s elektrickými časťami a kontaktmi! Hrozí nebezpečenstvo ohrozenia života!

Práce na elektrických konštrukčných častiach môže vykonávať iba odborník s príslušným oprávnením.

Po výmene dosky treba skontrolovať funkcie kotla. Hrozí nebezpečenstvo poranenia osôb spôsobené nesprávnym fungovaním kotla



Hlavním vypínačem ZAP/VYP přístroj nelze odpojit od elektrické sítě!

Hrozí nebezpečí úrazu elektrickým napětím na elektrických konstrukčních dílech. Nikdy se nedotýkejte elektrických částí a kontaktů, když zařízení není odpojeno od elektrické sítě. Hrozí nebezpečí ohrožení života!

Práce na elektrických konstrukčních dílech smí provádět pouze oprávněná osoba.

Po výměně desky je třeba provést kontrolu funkce. V opačném případě hrozí nebezpečí poranění osob způsobené nesprávnou funkcí kotle.

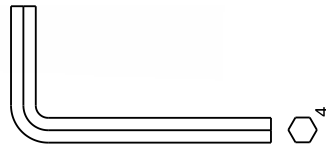

Art.Nr. 2745586



Art.Nr. 2745894

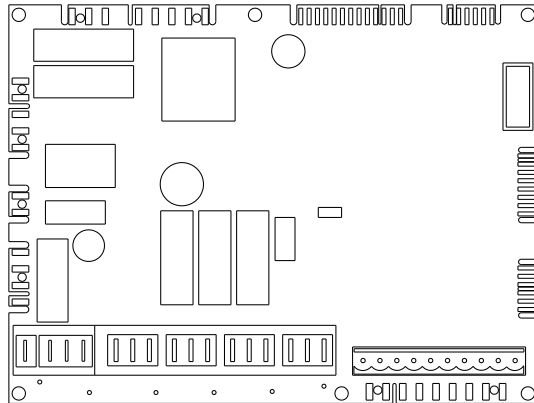

Art.Nr. 2745586



Art.Nr. 2745894

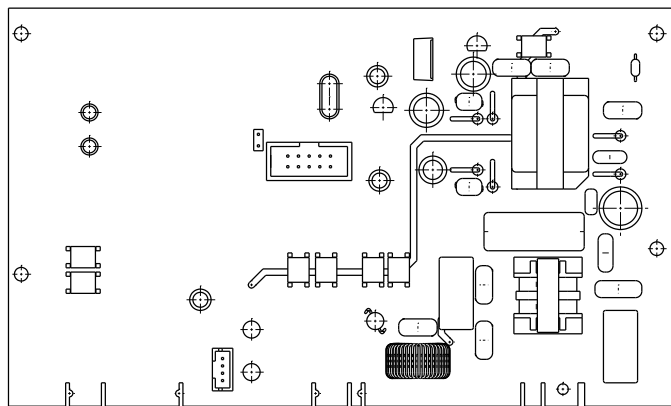



Art.Nr. 2745586



Art.Nr. 2745894

1.1

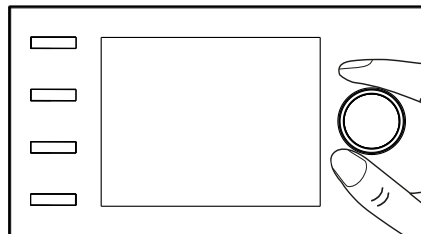

Parameter
WP001 WP121 + default settings

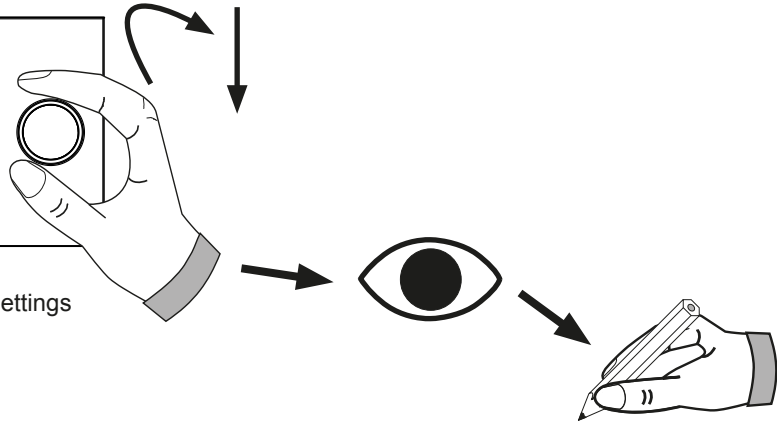

Nr.					
WP001		-	WP028		-
WP002		-	WP031		-
WP003		-	WP032		-
WP010		°C	WP033		-
WP011		°C	WP053		°C
WP012		Min	WP054		°C
WP013		Min	WP055		°C
WP014		Min	WP058		-
WP015		%	WP061		-
WP016		-	WP062		-
WP017		°C	WP064		%
WP018		°C	WP080		°C
WP020		°C	WP090		-
WP021		-	WP091		°C
WP022		Min	WP092		-
WP023		Min	WP093		Day
WP024		°C	WP094		kW
WP025		-	WP101		°C
WP026		°C	WP104		-
WP027		°C	WP121		h

Default settings:	
DHW operation mode	
DHW quick heating	
Night mode	
Active cooling	

1.2

Art.Nr. 2745586

Art.Nr. 2745894

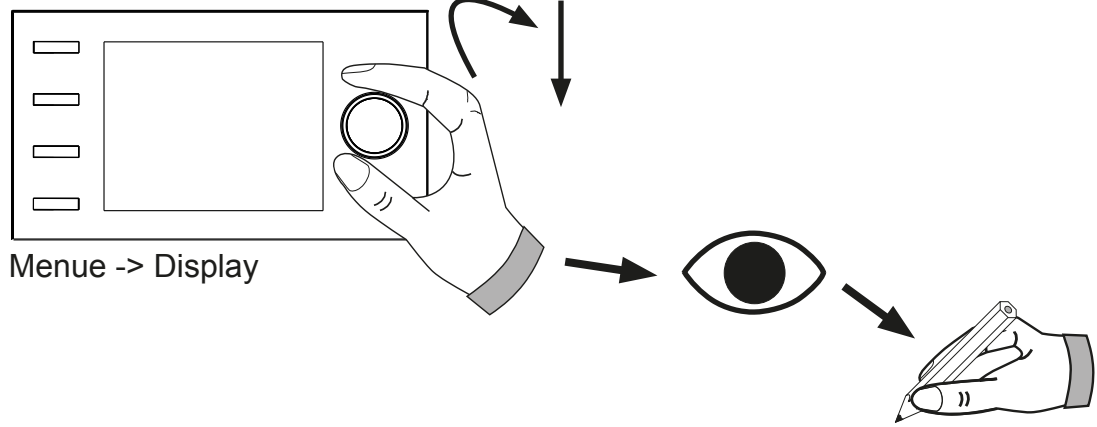

Only for Documentation:		
Heating energy amount		kWh
DHW energy amount		kWh
Cooling energy amount		kWh
Compressor hour run		hours
Elektric heater hour run		hours
Number of compressor starts		-

2

Art.Nr. 2745586

Art.Nr. 2745894

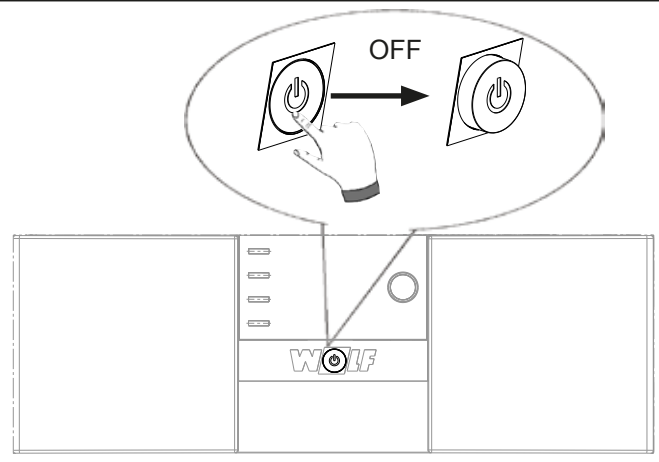

3

Art.Nr. 2745586

Art.Nr. 2745894

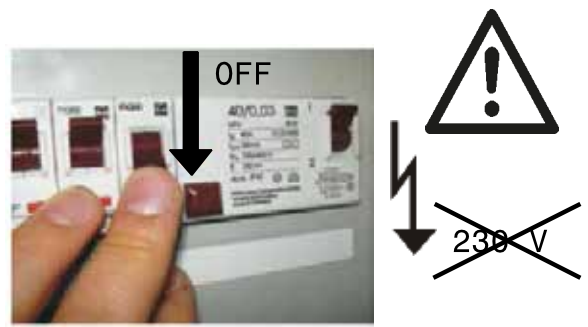

4



Art.Nr. 2745586



Art.Nr. 2745894

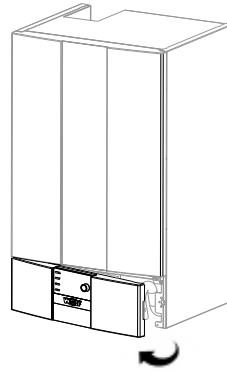

5



Art.Nr. 2745586



Art.Nr. 2745894

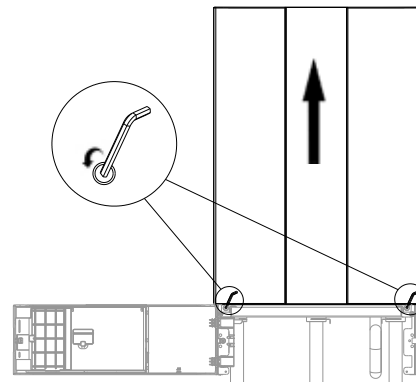

6



Art.Nr. 2745586



Art.Nr. 2745894

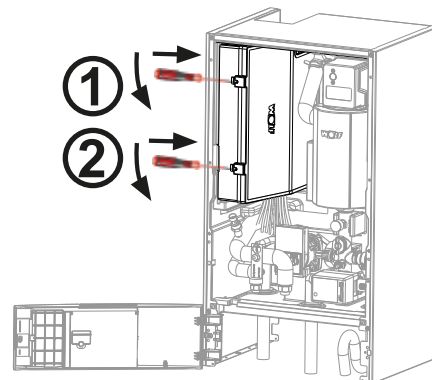

7



Art.Nr. 2745586



Art.Nr. 2745894

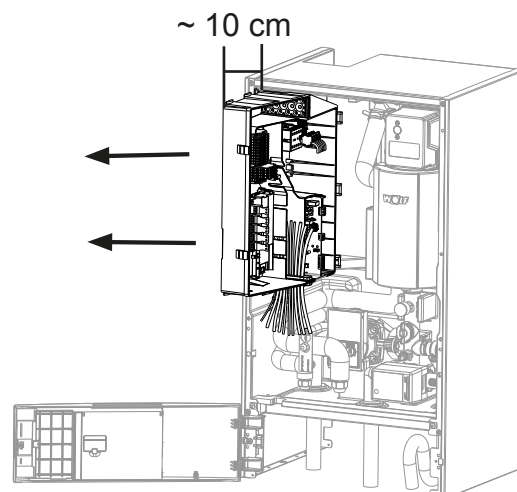

8



Art.Nr. 2745586



Art.Nr. 2745894

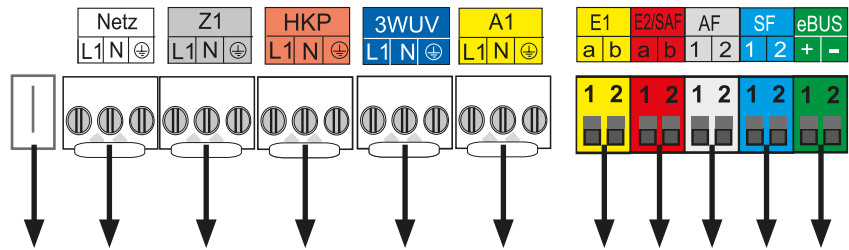
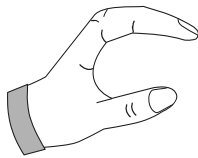

9



Art.Nr. 2745586



Art.Nr. 2745894

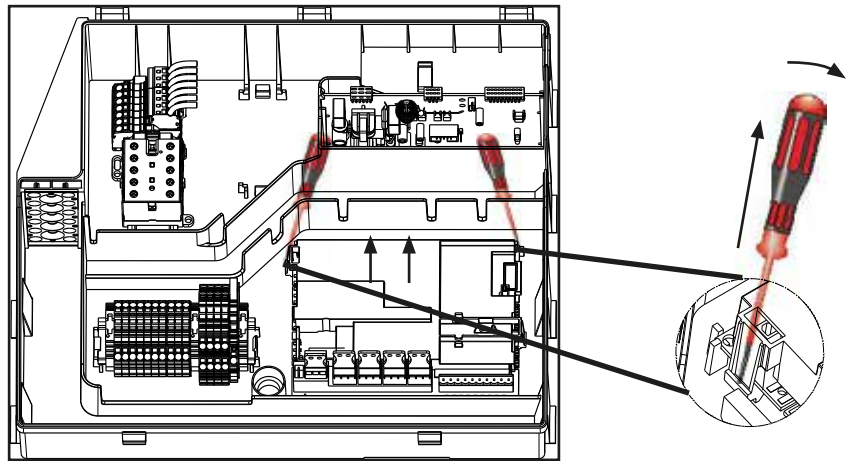

10



Art.Nr. 2745586



Art.Nr. 2745894

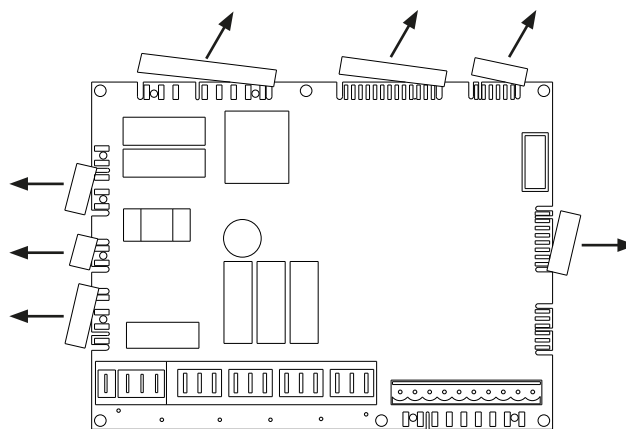

11



Art.Nr. 2745586



Art.Nr. 2745894

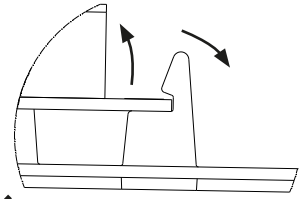
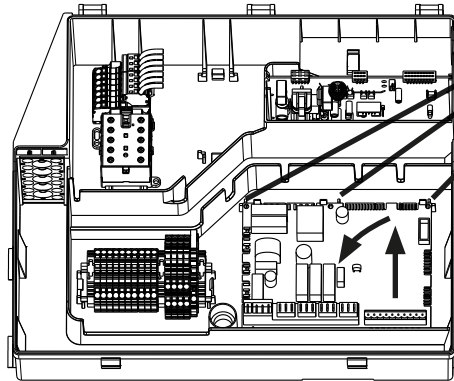

12



Art.Nr. 2745586



Art.Nr. 2745894

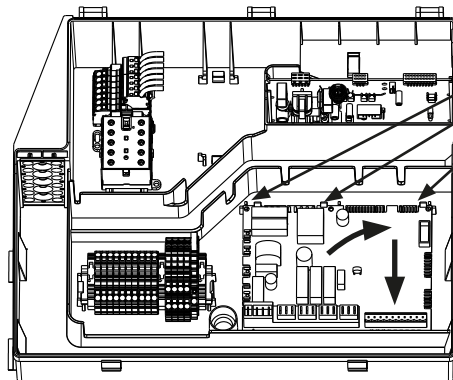

13



Art.Nr. 2745586



Art.Nr. 2745894

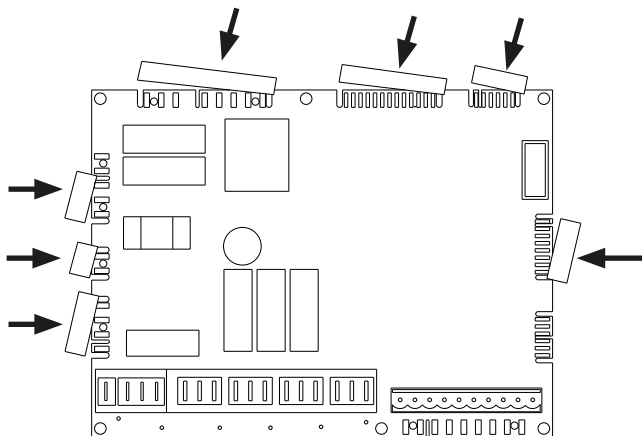

14

- Art.Nr. 2745586
- Art.Nr. 2745894

Click

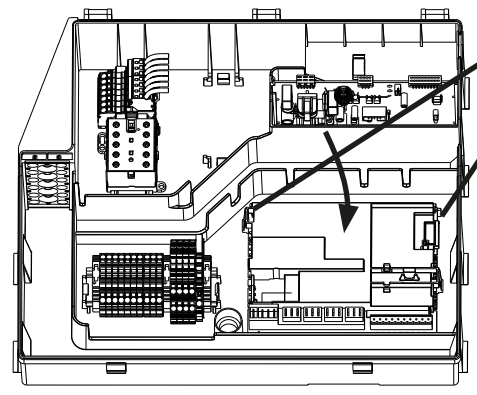

15

- Art.Nr. 2745586
- Art.Nr. 2745894

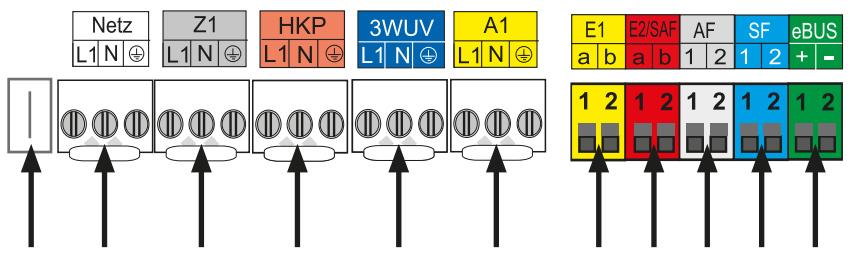
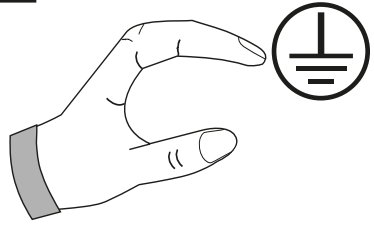

16

- Art.Nr. 2745586
- Art.Nr. 2745894

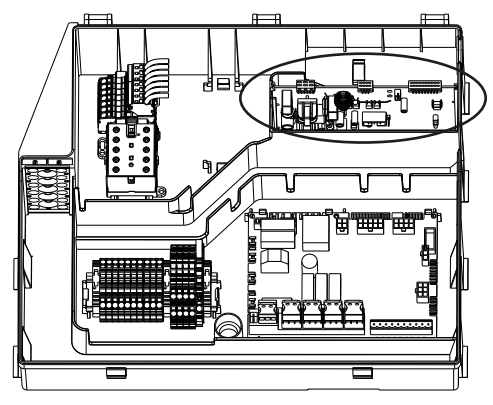

17



Art.Nr. 2745586



Art.Nr. 2745894

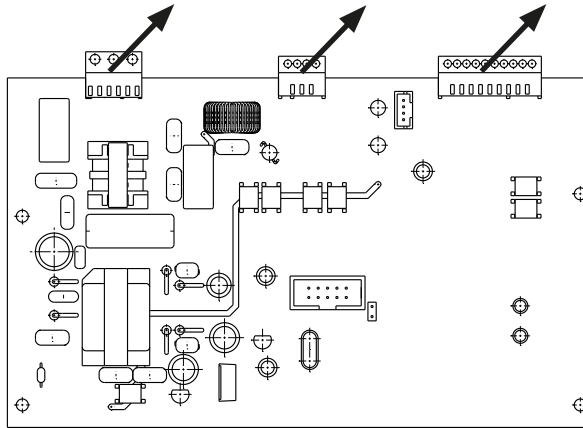

18



Art.Nr. 2745586



Art.Nr. 2745894

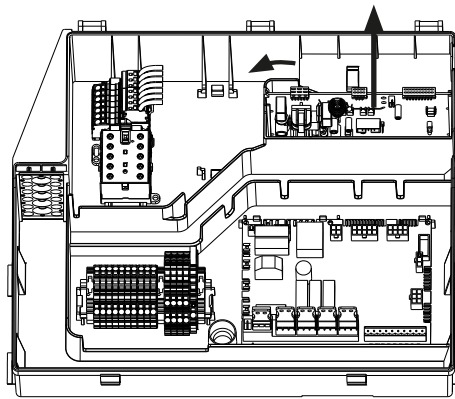

19



Art.Nr. 2745586



Art.Nr. 2745894

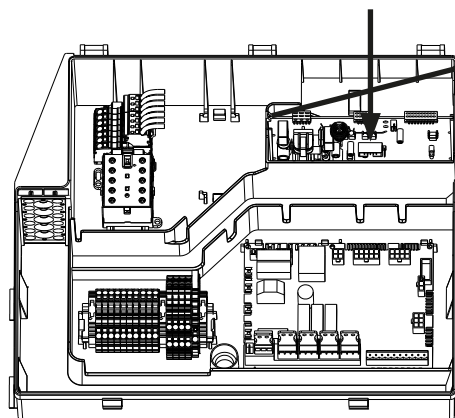

20



Art.Nr. 2745586



Art.Nr. 2745894

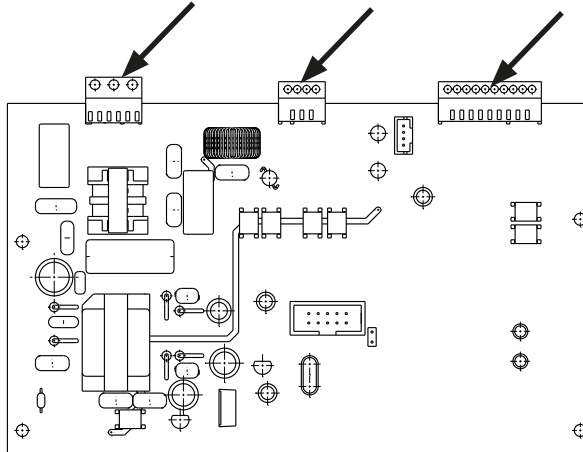

21



Art.Nr. 2745586



Art.Nr. 2745894

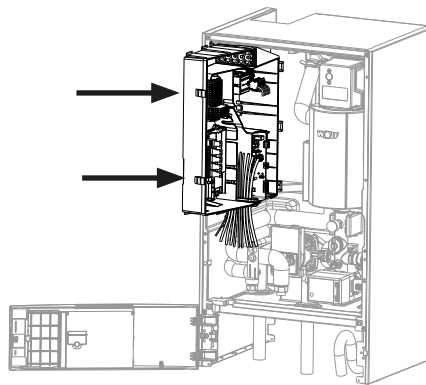

22



Art.Nr. 2745586



Art.Nr. 2745894

Click

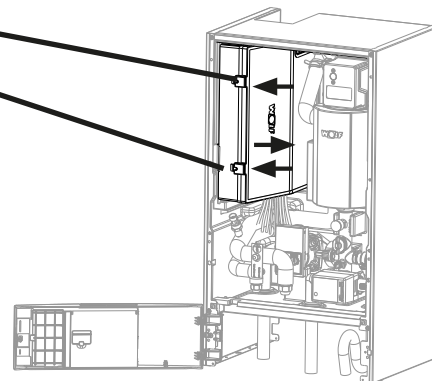

23



Art.Nr. 2745586



Art.Nr. 2745894

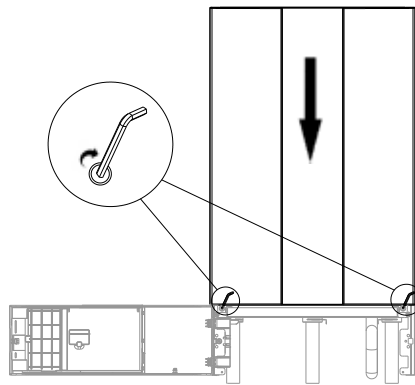

24



Art.Nr. 2745586



Art.Nr. 2745894

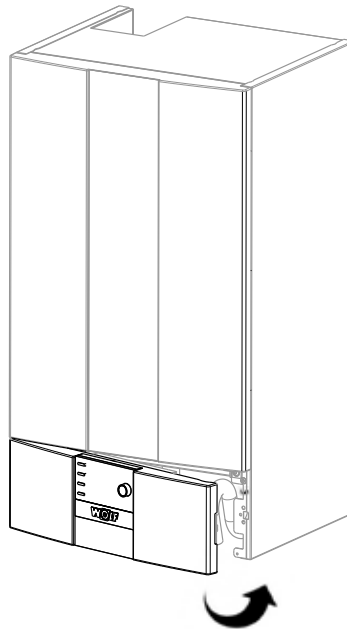

25



Art.Nr. 2745586



Art.Nr. 2745894

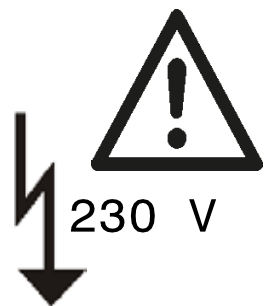

26



Art.Nr. 2745586



Art.Nr. 2745894

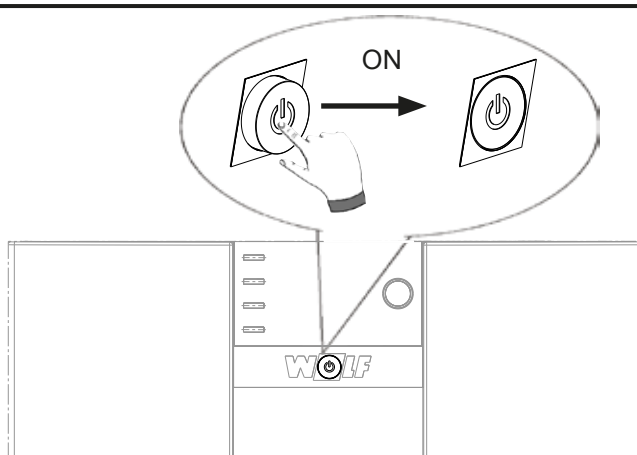

27



Art.Nr. 2745167



Art.Nr. 2745894

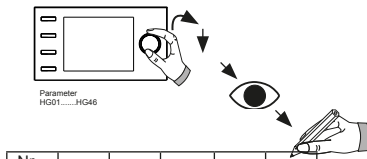

Nr.					
WP001	-		WP026		°C
WP002	-		WP027		°C
WP003	-		WP028		-
WP010		°C	WP031		-
WP011		°C	WP053		°C
WP012		Min	WP054		°C
WP013		Min	WP055		°C
WP014		Min	WP058		-
WP015		%	WP080		°C
WP016		-	WP090		-
WP017		°C	WP091		°C
WP018		°C	WP092		-
WP020		°C	WP093		Day
WP021		-	WP094		kW
WP022		Min	WP101		°C
WP023		Min	WP121		h
WP024		°C			
WP025		-			

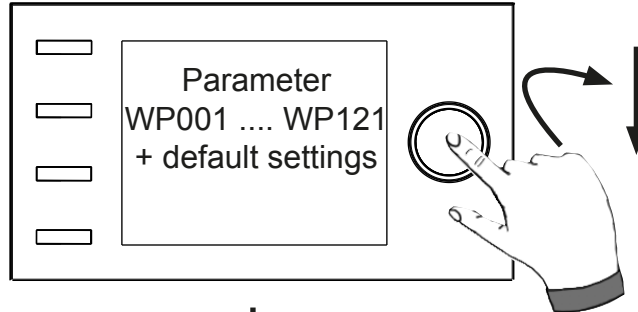

Sensor calibration

